



WE CONTRIBUTE TO A
**CIRCULAR
ECONOMY**

ECO-FRIENDLY PRODUCTION

Stäk Aluminum

PROFILES CATALOG

WWW.STAKALUMINUM.COM

2023

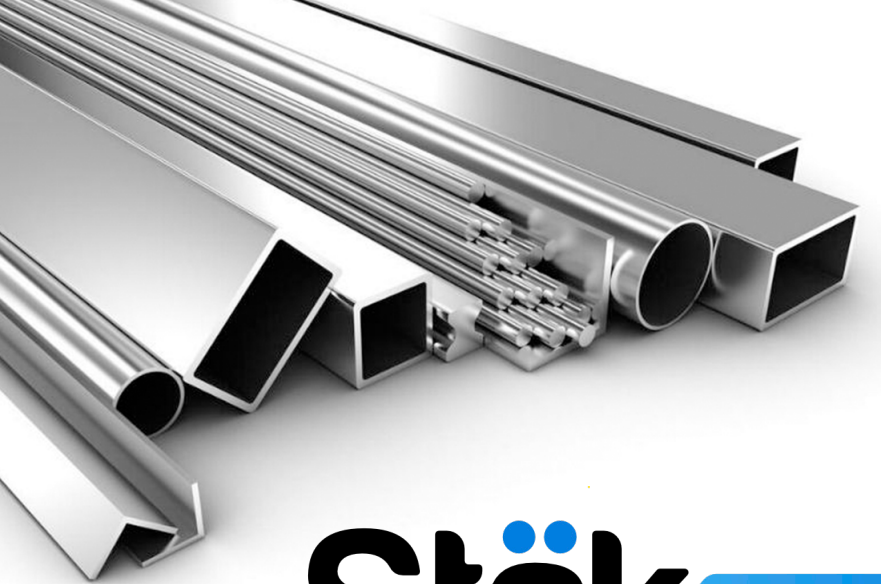

+30
YEARS OF
EXPERIENCE

Stäk Aluminum

Stäk Aluminum is a department of Stäk Glass LLC, which is part of a conglomerate that has over 30 years of experience in the Aluminum and Glass Business.

**SERVING THE US MARKET WITH
ZERO US TARIFFS AND SHORT
LEAD TIMES**

WE HAVE BUSINESSES ALONG THE
WHOLE ALUMINUM SUPPLY CHAIN
FROM SCRAP ALUMINUM RECYCLING,
TO ALUMINUM EXTRUSION,
TO ALUMINUM WHOLESALE AND
RETAIL, TO ALUMINUM WINDOWS,
DOORS AND ARCHITECTURAL
STRUCTURES.

WWW.STAKALUMINUM.COM



 WE CONTRIBUTE TO A
**CIRCULAR
ECONOMY**



We have a sustainable
production line.

STRATEGIC LOCATION



Stäk Aluminum is the authorized distributor for the US and Caribbean market of EXAL SA. We have the best strategic geographical position based in Colombia, South America taking advantage of the Free Trade Agreement FTA with the USA, and other countries in the Caribbean, Mexico, among others. That makes Stäk Aluminum highly competitive in Pricing and Timing. The lead times of our exports are 3 to 8 days sea freight, compared to Asian markets that not only have high US custom import tariffs but also the transit of 30 to 45 days sea freight.

TABLE OF CONTENTS

ARCHITECTURAL SYSTEMS

Sliding Windows and Doors	6
Casement Windows	7

NON-HOLLOW PROFILES

Solid Plate	8
Squared Bars	8
Channels	8
Channels with fin	8
Angles	9
Tees	9

HOLLOW PROFILES

Squared hollow tubes	10
Rounded hollow tubes	10
Rectangular hollow tubes	11
Hollow tubes with fin	12
Hollow tubes with double fin	12
Hollow tubes with Adapters	13
Door Profile	13

INTERIOR FINISHES

Wing	14
Stair ends	14
Blinds	14
Reticle	14

Glass Holders	14
Cornerbacks	15
Mosquito Net	15
Veneer	15
Handrails	15
Bathroom Divisions	16
Office Divisions	16
Closet Railing	16
Skirting Boards	17
Heat Sink	17

OTHER PROFILES

Standard Profiles	18
Patio Enclosures	19
Solar Panel Racks	21

AVAILABLE FINISHES 23

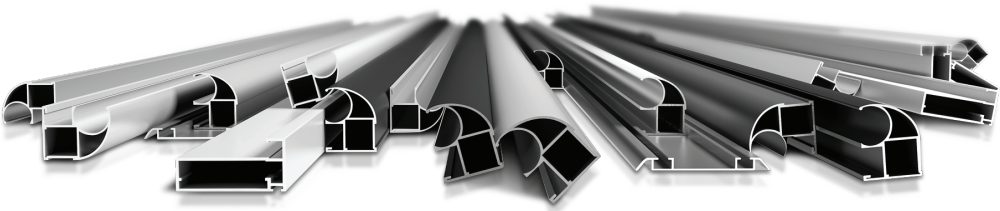

The material manufactured in our production plant complies with the ranges of mechanical properties and chemical composition, which are within the tolerances established by the technical standard **ASTM B221** "Standard Specification for Aluminum - Alloy Extruded Bars, Rods, Wire, Shapes and Tubes (Metric)"

SLIDING WINDOWS AND DOORS

Metric Unit: Millimeters and Inches

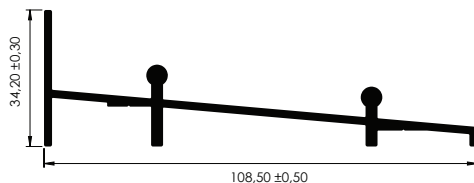

SILL

REF.	Weight		PER.	
	kg/m	lb/ft	mm	in
EXA775	1.108	0.744	353.33	13.91

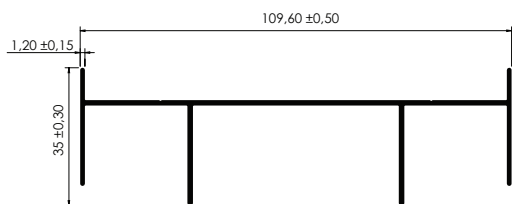

HEAD

REF.	Weight		PER.	
	kg/m	lb/ft	mm	in
EXA700	0.792	0.532	434.23	17.09

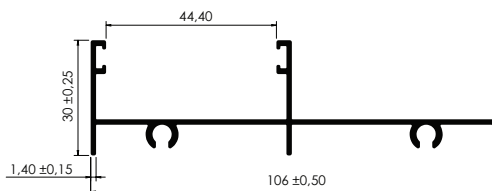

JAMB

REF.	Weight		PER.	
	kg/m	lb/ft	mm	in
EXA702	0.826	0.555	412.72	16.24

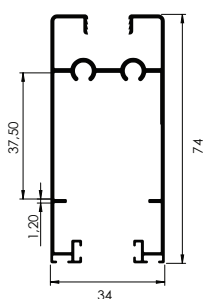

TOP/BOTTOM RAIL

REF.	Weight		PER.	
	kg/m	lb/ft	mm	in
EXA703	0.875	0.587	543.2	21.38

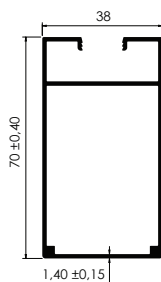

SIDE RAIL

REF.	Weight		PER.	
	kg/m	lb/ft	mm	in
EXA704	0.940	0.631	474.6	18.68

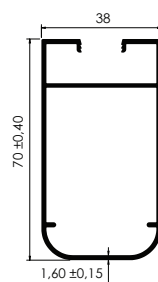

ROUNDED SIDE RAIL

REF.	Weight		PER.	
	kg/m	lb/ft	mm	in
EXAR704	0.996	0.669	468.12	18.42

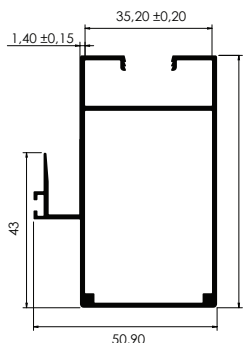

INTERLOCKER

REF.	Weight		PER.	
	kg/m	lb/ft	mm	in
EXA705	1.060	0.712	543.7	21.40

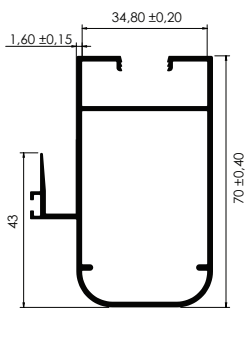

ROUNDED INTERLOCKER

REF.	Weight		PER.	
	kg/m	lb/ft	mm	in
EXAR705	1.128	0.757	536.41	21.11

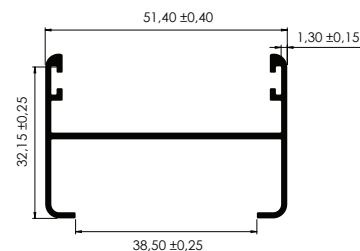

ADAPTER

REF.	Weight		PER.	
	kg/m	lb/ft	mm	in
EXA840	0.526	0.353	280.6	11.04

CASEMENT WINDOWS

Metric Unit: Millimeters and Inches

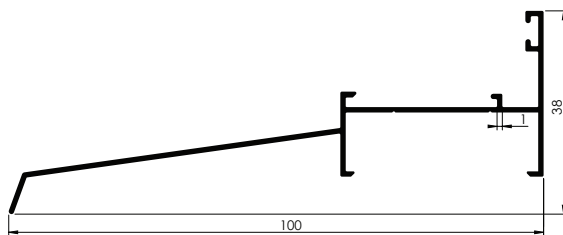

SILL WITH A DRIP

REF.	Weight		PER.	
	kg/m	lb/ft	mm	in
EXA626	0.450	0.302	330.7	13.02

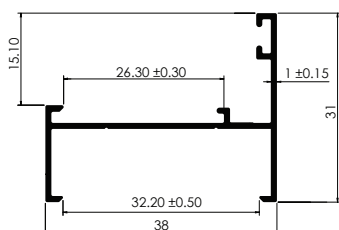

TOP/BOTTOM FRAME

REF.	Weight		PER.	
	kg/m	lb/ft	mm	in
EXA173	0.268	0.180	196.59	7.74

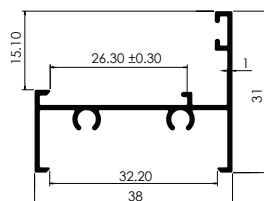

SIDE FRAME

REF.	Weight		PER.	
	kg/m	lb/ft	mm	in
EXA174	0.316	0.212	225.8	8.89

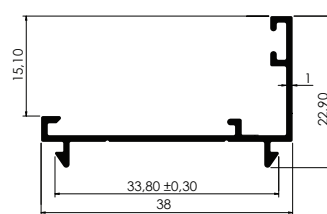

ADAPTER

REF.	Weight		PER.	
	kg/m	lb/ft	mm	in
EXA175	0.222	0.149	159.76	6.28

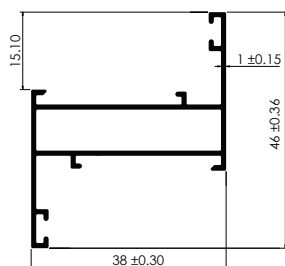

FRAME

REF.	Weight		PER.	
	kg/m	lb/ft	mm	in
EXA176	0.432	0.290	312.26	12.29

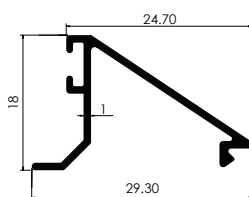

FLAT GLAZING

REF.	Weight		PER.	
	kg/m	lb/ft	mm	in
EXA177	0.169	0.113	119.71	4.71

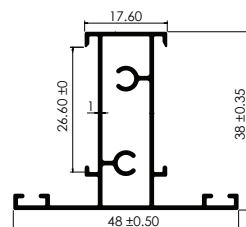

DIVIDER

REF.	Weight		PER.	
	kg/m	lb/ft	mm	in
EXA292	0.522	0.350	376.66	14.82

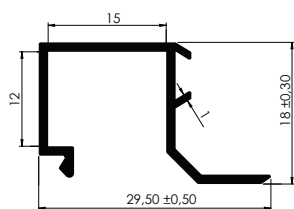

SQUARED GLAZING

REF.	Weight		PER.	
	kg/m	lb/ft	mm	in
EXA414	0.218	0.146	136.74	5.38

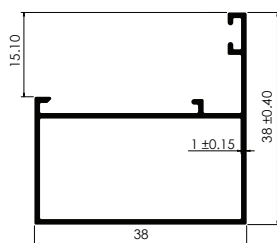

CORNERBACK

REF.	Weight		PER.	
	kg/m	lb/ft	mm	in
EXA416	0.395	0.265	287.8	11.33

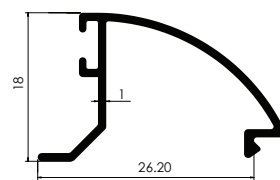

CURVED GLAZING

REF.	Weight		PER.	
	kg/m	lb/ft	mm	in
EXA635	0.175	0.117	126.9	4.99

NON-HOLLOW PROFILES

Metric Unit: Millimeters and Inches

SQUARED BARS

SOLID PLATE

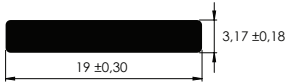

3/4" PLATE

REF.	Weight		PER.	
	kg/m	lb/ft	mm	in
P012	0.162	0.108	43.48	1.71

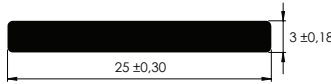

1" PLATE

REF.	Weight		PER.	
	kg/m	lb/ft	mm	in
P018	0.216	0.145	55.14	2.17

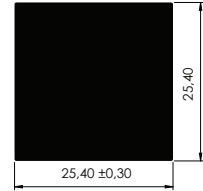

1" BAR

REF.	Weight		PER.	
	kg/m	lb/ft	mm	in
C009	1.748	1.17	101.1	3.98

CHANNELS

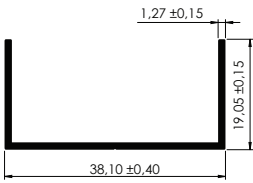

1-1/2" X 3/4" CHANNEL

REF.	Weight		PER.	
	kg/m	lb/ft	mm	in
ESC001	0.253	0.170	149.28	5.87

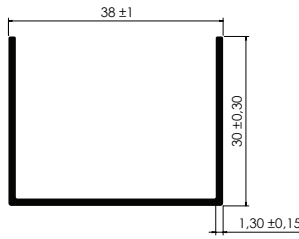

38MM X 30MM CHANNEL

REF.	Weight		PER.	
	kg/m	lb/ft	mm	in
EXA1870	0.336	0.225	192.2	7.56

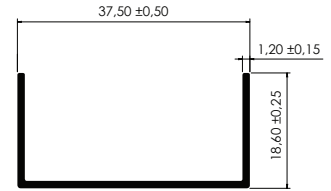

37.4MM X 18.6MM CHANNEL

REF.	Weight		PER.	
	kg/m	lb/ft	mm	in
EXA1872	0.235	0.157	145.8	5.74

CHANNELS WITH FIN

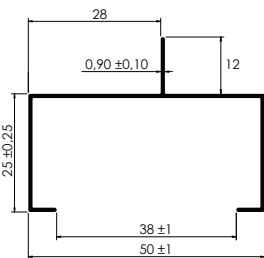

2" X 1" CHANNEL

REF.	Weight		PER.	
	kg/m	lb/ft	mm	in
U066	0.293	0.196	140.1	5.51

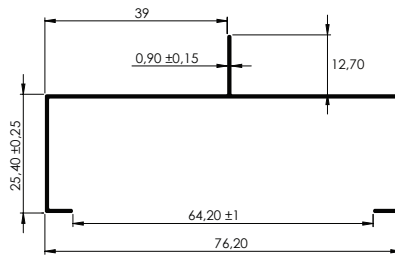

3" X 1" CHANNEL

REF.	Weight		PER.	
	kg/m	lb/ft	mm	in
U078	0.361	0.242	295.64	11.64

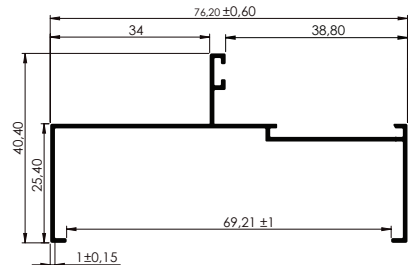

3" X 1" CHANNEL

REF.	Weight		PER.	
	kg/m	lb/ft	mm	in
U078E	0.429	0.288	314.62	12.38

ANGLES

TEES

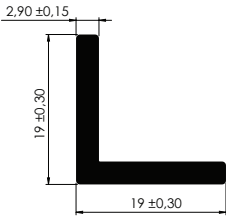

3/4" ANGLE

REF.	Weight		PER.	
	kg/m	lb/ft	mm	in
A006	0.275	0.184	74.9	2.94

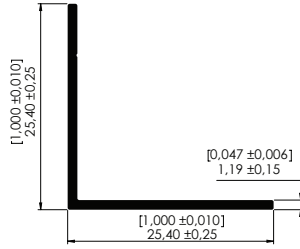

1" ANGLE

REF.	Weight		PER.	
	kg/m	lb/ft	mm	in
A009	0.160	0.107	101.02	3.97

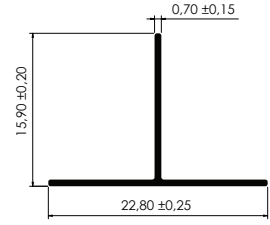

LOW CEILING TEE

REF.	Weight		PER.	
	kg/m	lb/ft	mm	in
D028	0.072	0.048	76.54	3.01

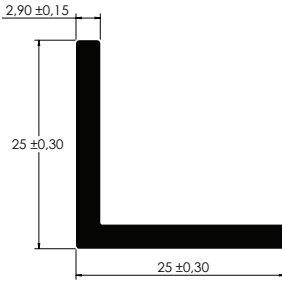

1" ANGLE

REF.	Weight		PER.	
	kg/m	lb/ft	mm	in
A011	0.370	0.248	99.03	3.89

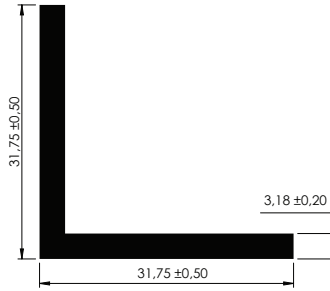

1-1/4" ANGLE

REF.	Weight		PER.	
	kg/m	lb/ft	mm	in
A015	0.518	0.348	127	5

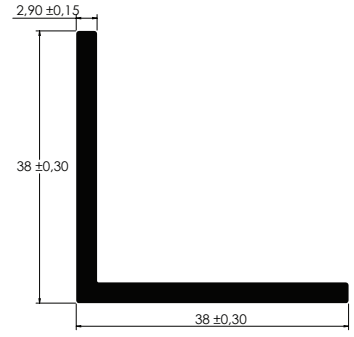

1-1/2" ANGLE

REF.	Weight		PER.	
	kg/m	lb/ft	mm	in
A019	0.574	0.385	151	5.94

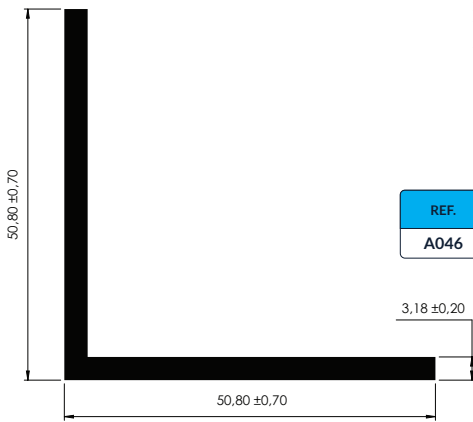

2" ANGLE

REF.	Weight		PER.	
	kg/m	lb/ft	mm	in
A027	0.845	0.567	203.2	8

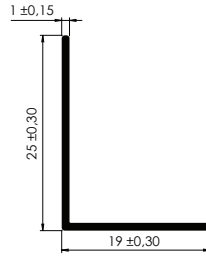

1" X 3/4" ANGLE

REF.	Weight		PER.	
	kg/m	lb/ft	mm	in
A046	0.116	0.077	87.1	3.42

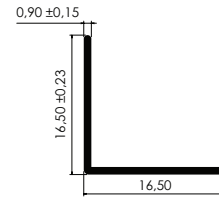

LOW CEILING ANGLE

REF.	Weight		PER.	
	kg/m	lb/ft	mm	in
A059	0.078	0.052	64.97	2.55

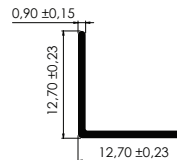

1/2" ANGLE

REF.	Weight		PER.	
	kg/m	lb/ft	mm	in
A061	0.059	0.039	49.71	1.95

HOLLOW PROFILES

Metric Unit: Millimeters and Inches

SQUARED HOLLOW TUBES

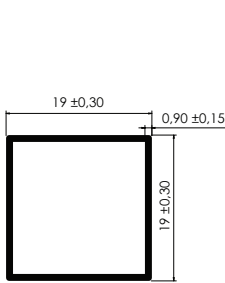

3/4" HOLLOW TUBE

REF.	Weight		PER.	
	kg/m	lb/ft	mm	in
T115	0.176	0.118	144.1	5.67

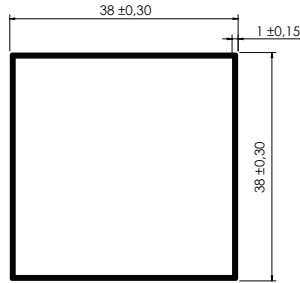

1-1/2" HOLLOW TUBE

REF.	Weight		PER.	
	kg/m	lb/ft	mm	in
T215	0.401	0.269	295.31	11.62

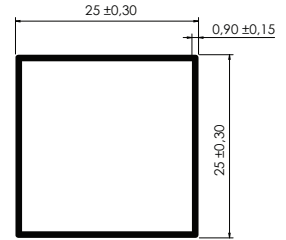

1" HOLLOW TUBE

REF.	Weight		PER.	
	kg/m	lb/ft	mm	in
T216	0.235	0.157	192.11	7.56

ROUNDED HOLLOW TUBES

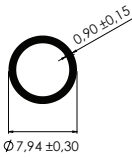

5/16" HOLLOW TUBE

REF.	Weight		PER.	
	kg/m	lb/ft	mm	in
TC002	0.054	0.036	44.23	1.74

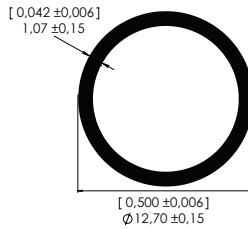

1/2" HOLLOW TUBE

REF.	Weight		PER.	
	kg/m	lb/ft	mm	in
TC008	0.106	0.071	73.07	2.87

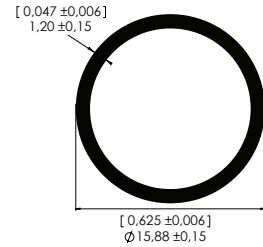

5/8" HOLLOW TUBE

REF.	Weight		PER.	
	kg/m	lb/ft	mm	in
TC012	0.150	0.101	92.21	3.63

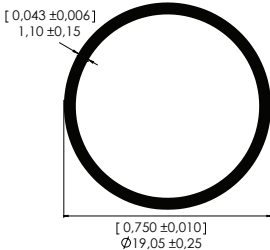

3/4" HOLLOW TUBE

REF.	Weight		PER.	
	kg/m	lb/ft	mm	in
TC013	0.168	0.113	112.78	4.44

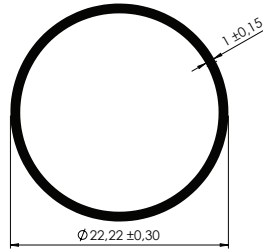

7/8" HOLLOW TUBE

REF.	Weight		PER.	
	kg/m	lb/ft	mm	in
TC017	0.181	0.121	133.3	5.24

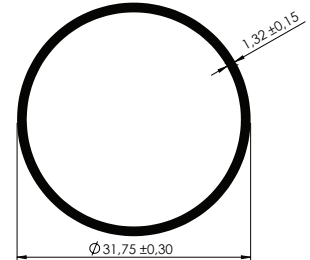

1-1/4" HOLLOW TUBE

REF.	Weight		PER.	
	kg/m	lb/ft	mm	in
TC027	0.342	0.229	191.2	7.52

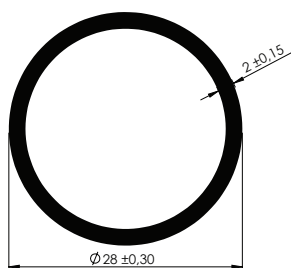

1-1/4" HOLLOW TUBE

REF.	Weight		PER.	
	kg/m	lb/ft	mm	in
TC028	0.441	0.296	163.36	6.43

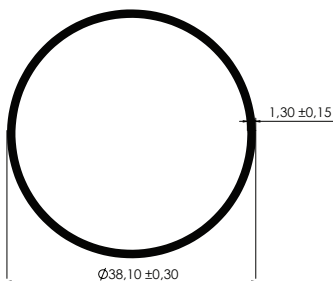

1-1/2" HOLLOW TUBE

REF.	Weight		PER.	
	kg/m	lb/ft	mm	in
TC031	0.407	0.273	231.2	9.10

RECTANGULAR HOLLOW TUBES

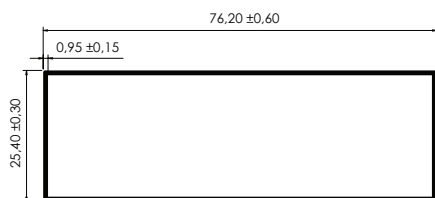

3" X 1" HOLLOW TUBE

REF.	Weight		PER.	
	kg/m	lb/ft	mm	in
T094	0.513	0.345	398.1	15.67

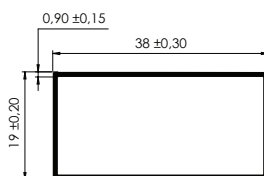

1-1/2" X 3/4" HOLLOW TUBE

REF.	Weight		PER.	
	kg/m	lb/ft	mm	in
T097	0.269	0.180	220	8.66

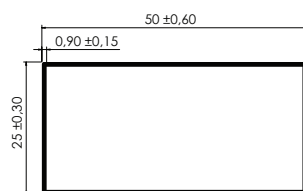

2" X 1" HOLLOW TUBE

REF.	Weight		PER.	
	kg/m	lb/ft	mm	in
T117	0.357	0.239	292.11	11.50

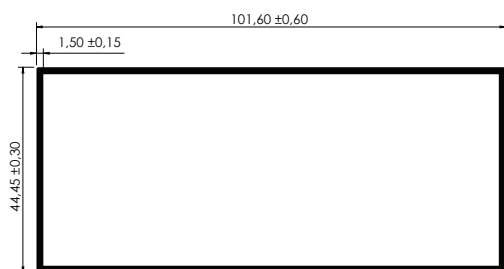

4" X 1-3/4" HOLLOW TUBE

REF.	Weight		PER.	
	kg/m	lb/ft	mm	in
T101	1.163	0.781	571.52	22.50

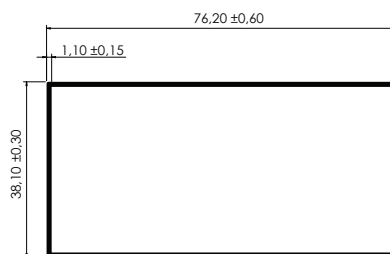

3" X 1-1/2" HOLLOW TUBE

REF.	Weight		PER.	
	kg/m	lb/ft	mm	in
T103	0.668	0.448	447.71	17.62

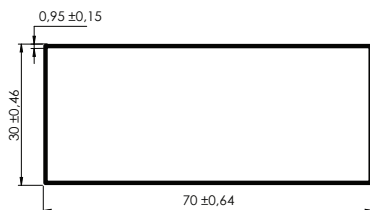

70MM X 30MM HOLLOW TUBE

REF.	Weight		PER.	
	kg/m	lb/ft	mm	in
T167	0.505	0.339	391.28	15.40

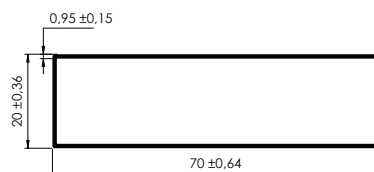

70MM X 20MM HOLLOW TUBE

REF.	Weight		PER.	
	kg/m	lb/ft	mm	in
T168	0.453	0.304	351.28	13.82

HOLLOW TUBES WITH FINS

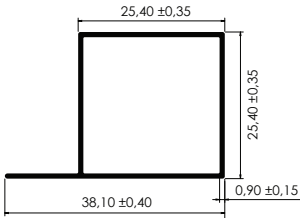

1" HOLLOW TUBE WITH FIN

REF.	Weight		PER.	
	kg/m	lb/ft	mm	in
T077	0.270	0.181	219.96	8.66

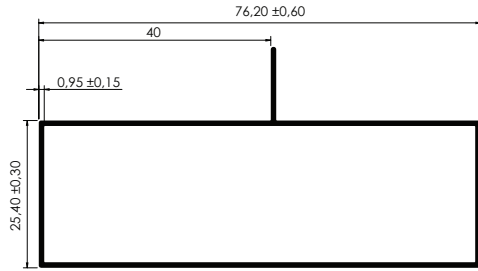

3" X 1" HOLLOW TUBE WITH FIN

REF.	Weight		PER.	
	kg/m	lb/ft	mm	in
T095	0.545	0.366	422.72	16.64

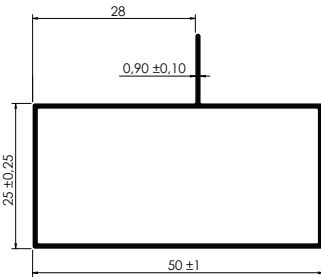

2" X 1" HOLLOW TUBE WITH OFFSET FIN

REF.	Weight		PER.	
	kg/m	lb/ft	mm	in
TA037	0.386	0.259	315.1	12.40

HOLLOW TUBES WITH DOUBLE FINS

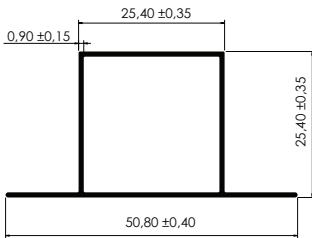

1" HOLLOW TUBE WITH DOUBLE FIN

REF.	Weight		PER.	
	kg/m	lb/ft	mm	in
T078	0.301	0.202	245.17	9.65

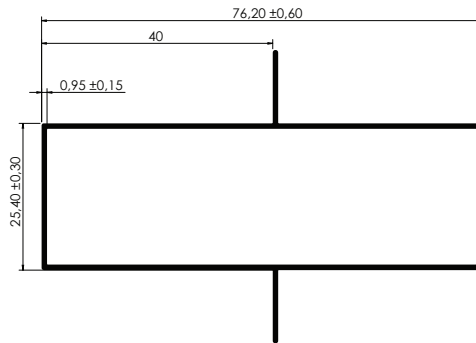

3" X 1" HOLLOW TUBE WITH DOUBLE FIN

REF.	Weight		PER.	
	kg/m	lb/ft	mm	in
T096	0.578	0.388	447.6	17.62

DOOR PROFILE

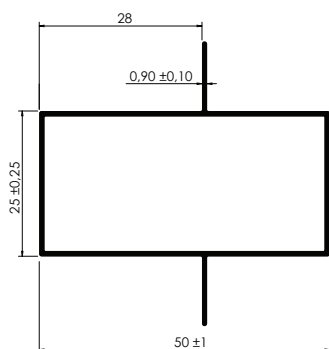

2" X 1" HOLLOW TUBE WITH DOUBLE OFFSET FIN

REF.	Weight		PER.	
	kg/m	lb/ft	mm	in
TA100	0.594	0.399	339.38	13.36

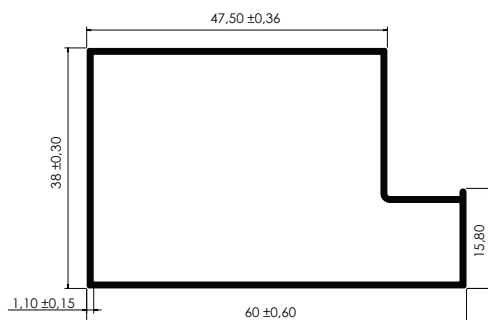

TUBULITE

REF.	Weight		PER.	
	kg/m	lb/ft	mm	in
TA005	0.573	0.385	383.24	15.08

HOLLOW TUBES WITH ADAPTERS

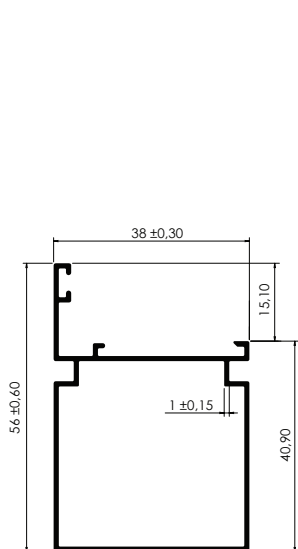

1-1/2" HOLLOW TUBE WITH ADAPTER

REF.	Weight		PER.	
	kg/m	lb/ft	mm	in
EXA1101	0.514	0.345	373.99	14.72

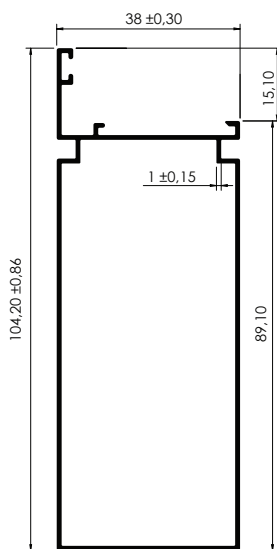

3" X 1" HOLLOW TUBE WITH ADAPTER

REF.	Weight		PER.	
	kg/m	lb/ft	mm	in
EXA1102	0.775	0.520	566.79	22.31

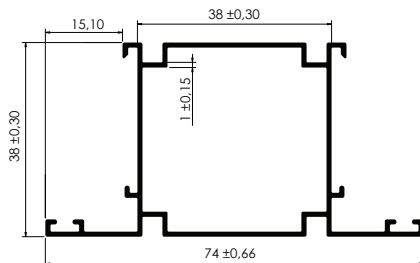

1-1/2" HOLLOW TUBE WITH DOUBLE ADAPTER

REF.	Weight		PER.	
	kg/m	lb/ft	mm	in
EXA1103	0.627	0.421	453.1	17.83

INTERIOR FINISHES PROFILES

Metric Unit: Millimeters and Inches

WING ——— STAIR ENDS ——— RETICLE ———

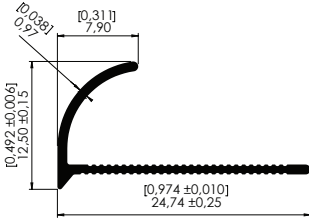

SPANISH WING

REF.	Weight		PER.	
	kg/m	lb/ft	mm	in
CEO031	0.097	0.065	86.38	3.40

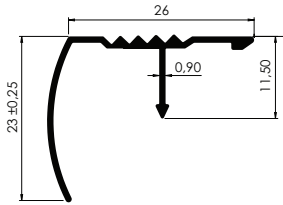

STAIR END

REF.	Weight		PER.	
	kg/m	lb/ft	mm	in
S390	0.186	0.124	130	5.11

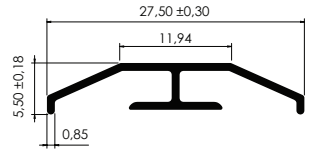

RETICLE

REF.	Weight		PER.	
	kg/m	lb/ft	mm	in
EXA511	0.102	0.068	88.79	3.49

BLINDS ——— GLASS HOLDERS ———

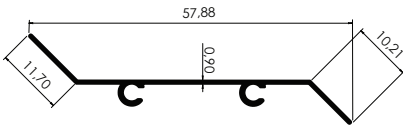

BLINDS

REF.	Weight		PER.	
	kg/m	lb/ft	mm	in
EXA315	0.193	0.129	150.62	5.92

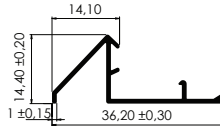

GLASS HOLDER (FEMALE)

REF.	Weight		PER.	
	kg/m	lb/ft	mm	in
S343	0.175	0.117	127.98	5.03

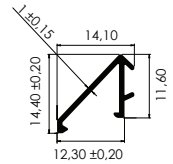

GLASS HOLDER (MALE)

REF.	Weight		PER.	
	kg/m	lb/ft	mm	in
S344	0.094	0.063	68.92	2.71

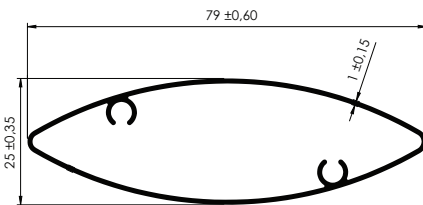

SUN BLINDS

REF.	Weight		PER.	
	kg/m	lb/ft	mm	in
T237	0.521	0.350	374.62	14.75

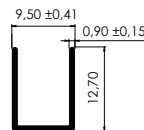

3/8" X 1/2" CHANNEL

REF.	Weight		PER.	
	kg/m	lb/ft	mm	in
U068	0.080	0.053	66.67	2.62

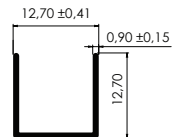

1/2" X 1/2" CHANNEL

REF.	Weight		PER.	
	kg/m	lb/ft	mm	in
U074	0.088	0.059	73.07	2.87

CORNERBACKS

MOSQUITO NET

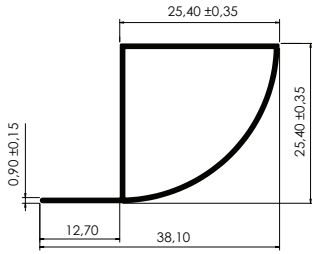

1" CORNERBACK WITH WING

REF.	Weight		PER.	
	kg/m	lb/ft	mm	in
T281	0.244	0.164	199.1	7.83

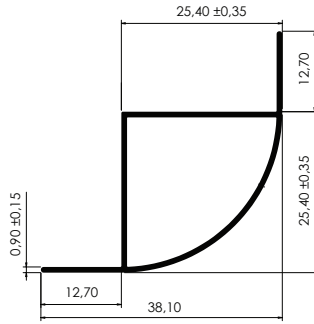

1" CORNERBACK WITH DOUBLE WING

REF.	Weight		PER.	
	kg/m	lb/ft	mm	in
T282	0.274	0.184	224.1	8.82

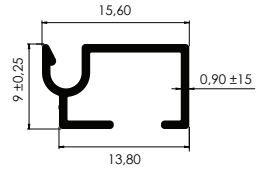

MOSQUITO NET

REF.	Weight		PER.	
	kg/m	lb/ft	mm	in
EXA165	0.103	0.069	83.7	3.29

VENEER

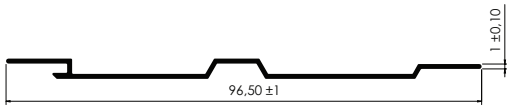

FLAT VENEER

REF.	Weight		PER.	
	kg/m	lb/ft	mm	in
F006	0.291	0.195	214.43	8.44

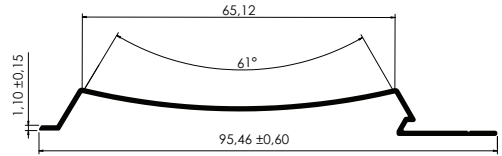

CURVED VENEER

REF.	Weight		PER.	
	kg/m	lb/ft	mm	in
F007	0.291	0.195	214.43	8.44

HANDRAILS

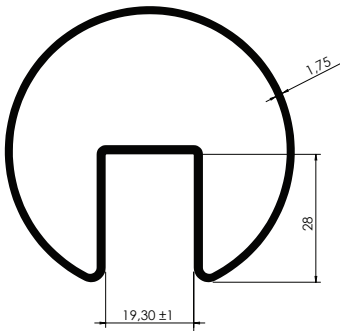

2-1/2" HANDRAIL

REF.	Weight		PER.	
	kg/m	lb/ft	mm	in
EXA736	1.221	0.820	492.52	19.39

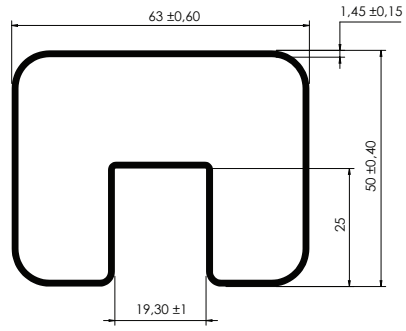

ANATOMIC HANDRAIL

REF.	Weight		PER.	
	kg/m	lb/ft	mm	in
EXA737	1.001	0.672	509.5	20.05

BATHROOM DIVISIONS

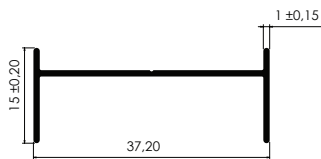

SIDE FRAME

REF.	Weight		PER.	
	kg/m	lb/ft	mm	in
EXA343	0.175	0.117	130.43	5.13

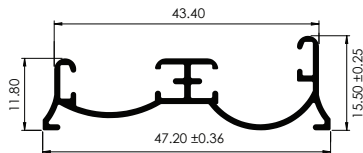

VT BOTTOM RAIL

REF.	Weight		PER.	
	kg/m	lb/ft	mm	in
EXA1768	0.304	0.204	218.2	8.59

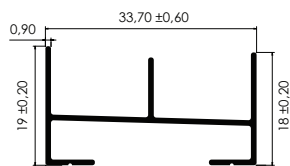

SILL

REF.	Weight		PER.	
	kg/m	lb/ft	mm	in
S597	0.224	0.150	183.4	7.22

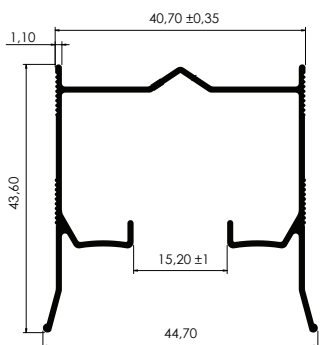

HANGING RAIL

REF.	Weight		PER.	
	kg/m	lb/ft	mm	in
EXA346	0.450	0.302	326.61	12.85

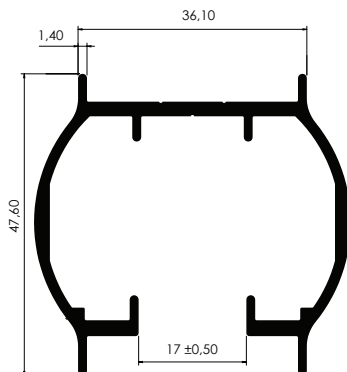

VT HANGING RAIL

REF.	Weight		PER.	
	kg/m	lb/ft	mm	in
EXA1769	0.879	0.590	331.77	13.06

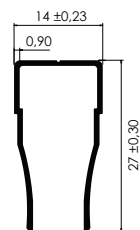

LIGHTWEIGHT "U" CHANNEL

REF.	Weight		PER.	
	kg/m	lb/ft	mm	in
S596	0.164	0.110	134.86	5.30

CLOSET RAILING

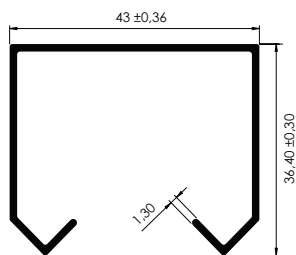

CLOSET HANGING RAIL

REF.	Weight		PER.	
	kg/m	lb/ft	mm	in
S391	0.462	0.310	262.26	10.32

OFFICE DIVISIONS

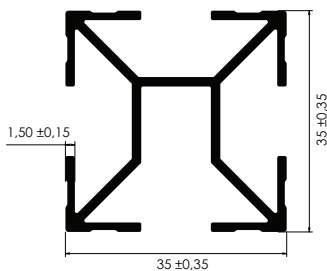

CENTER POST

REF.	Weight		PER.	
	kg/m	lb/ft	mm	in
EXA405	0.706	0.474	349.4	13.75

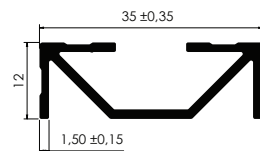

HALF CENTER POST

REF.	Weight		PER.	
	kg/m	lb/ft	mm	in
EXA-A405	0.330	0.221	164.9	6.49

SKIRTING BOARDS

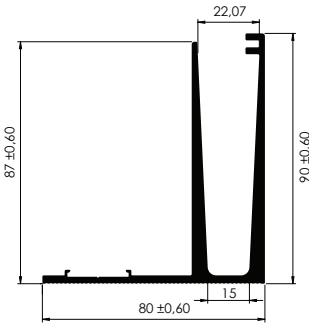

TEMPERED GLASS SKIRTING BOARD

REF.	Weight		PER.	
	kg/m	lb/ft	mm	in
S001	2.727	1.832	528.99	20.82

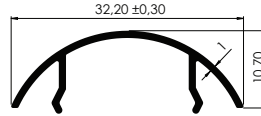

SKIRTING BOARD COVER

REF.	Weight		PER.	
	kg/m	lb/ft	mm	in
S002	0.151	0.101	111.26	4.38

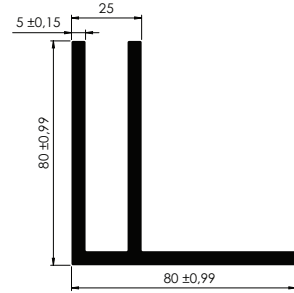

SKIRTING BOARD FOR HANDRAIL

REF.	Weight		PER.	
	kg/m	lb/ft	mm	in
S003	3.116	2.093	467.9	18.42

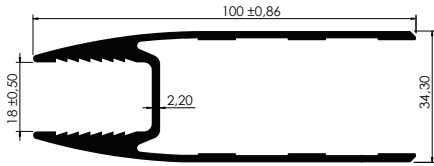

100MM SKIRTING BOARD

REF.	Weight		PER.	
	kg/m	lb/ft	mm	in
S351L	1.676	1.126	485.05	19.09

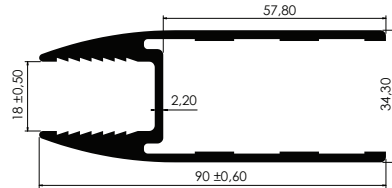

90MM SKIRTING BOARD

REF.	Weight		PER.	
	kg/m	lb/ft	mm	in
S369	1.797	1.207	447.99	17.63

HEAT SINK

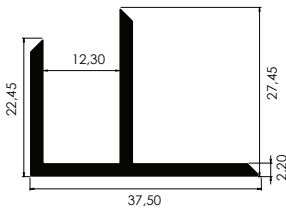

"F" FOR TEMPERED GLASS

REF.	Weight		PER.	
	kg/m	lb/ft	mm	in
S463	0.502	0.337	166.2	6.54

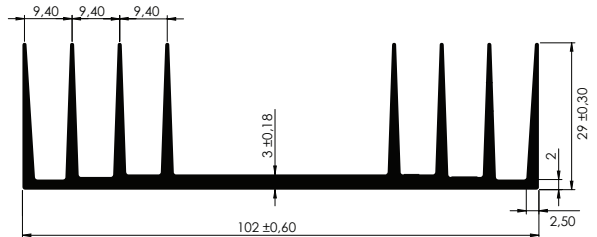

HEAT SINK

REF.	Weight		PER.	
	kg/m	lb/ft	mm	in
DIS001	1.715	1.152	612.1	24.09

OTHER PROFILES

Metric Unit: Millimeters and Inches

STANDARD PROFILES

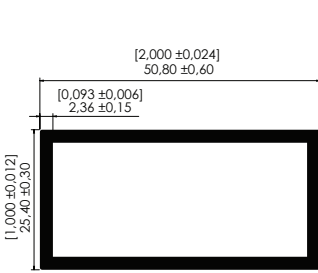

2" X 1" HOLLOW TUBE

REF.	Weight		PER.	
	kg/m	lb/ft	mm	in
EU001	0.914	0.614	285.23	11.23

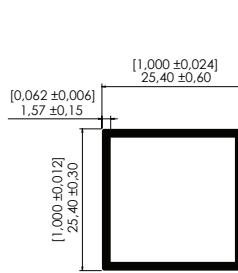

1" X 1" HOLLOW TUBE

REF.	Weight		PER.	
	kg/m	lb/ft	mm	in
EU002	0.405	0.272	189.95	7.47

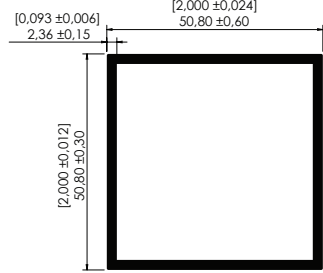

2" X 2" HOLLOW TUBE

REF.	Weight		PER.	
	kg/m	lb/ft	mm	in
EU003	1.239	0.832	386.83	15.23

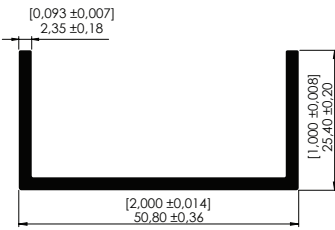

2" X 1" CHANNEL

REF.	Weight		PER.	
	kg/m	lb/ft	mm	in
EU004	0.617	0.414	197.3	7.67

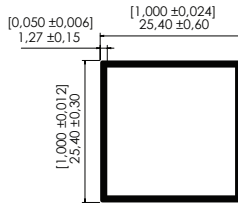

1" X 1" HOLLOW TUBE

REF.	Weight		PER.	
	kg/m	lb/ft	mm	in
EU005	0.332	0.223	192.35	7.57

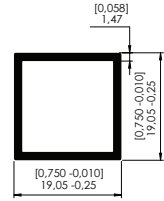

3/4" X 3/4" HOLLOW TUBE

REF.	Weight		PER.	
	kg/m	lb/ft	mm	in
EU006	0.281	0.188	139.8	5.50

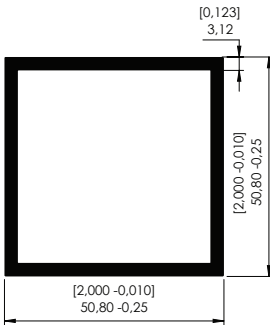

2" X 2" HOLLOW TUBE

REF.	Weight		PER.	
	kg/m	lb/ft	mm	in
EU007	1.614	1.084	380.64	14.98

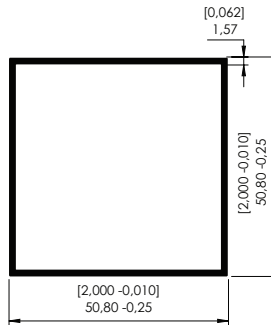

2" X 2" HOLLOW TUBE

REF.	Weight		PER.	
	kg/m	lb/ft	mm	in
EU008	0.840	0.564	393	15.47

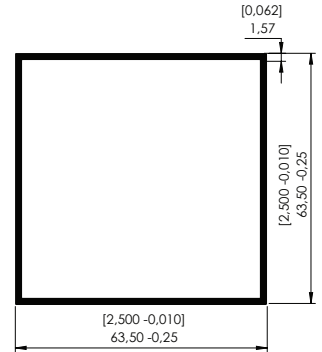

2-1/2" X 2-1/2" HOLLOW TUBE

REF.	Weight		PER.	
	kg/m	lb/ft	mm	in
EU009	1.189	0.798	493	19.41

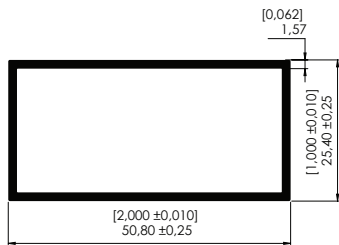

2" X 1" HOLLOW TUBE

REF.	Weight		PER.	
	kg/m	lb/ft	mm	in
EU010	0.623	0.418	291.4	11.47

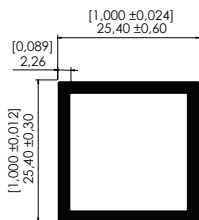

1" X 1" HOLLOW TUBE

REF.	Weight		PER.	
	kg/m	lb/ft	mm	in
EU011	0.567	0.381	184.4	7.26

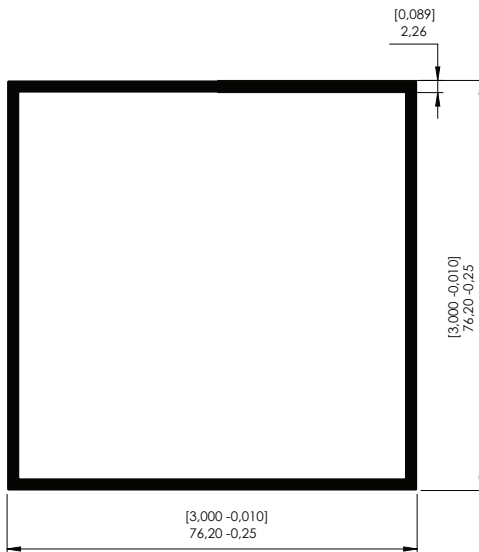

3" X 3" HOLLOW TUBE

REF.	Weight		PER.	
	kg/m	lb/ft	mm	in
EU012	1.811	1.216	590.8	23.26

PATIO ENCLOSURES

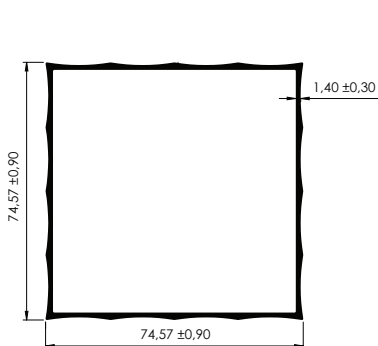

3" X 3" HOLLOW TUBE

REF.	Weight		PER.	
	kg/m	lb/ft	mm	in
AS001	1.286	0.864	579.25	22.80

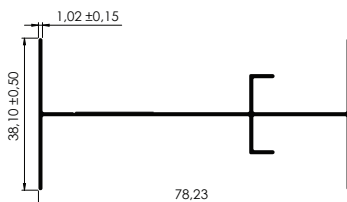

REF.	Weight		PER.	
	kg/m	lb/ft	mm	in
AS002	0.498	0.334	361.82	14.24

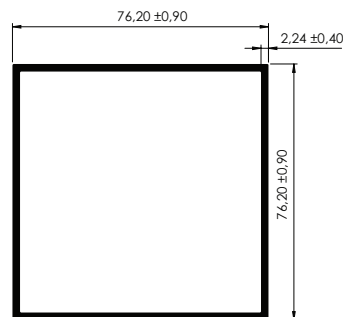

3" X 3" HOLLOW TUBE

REF.	Weight		PER.	
	kg/m	lb/ft	mm	in
AS003	1.789	1.202	590.31	23.24

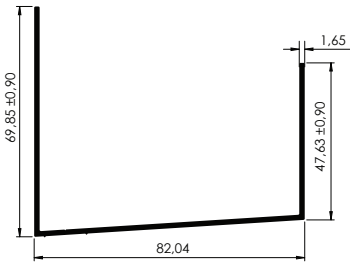

3" EXTRUDED HEADER

REF.	Weight		PER.	
	kg/m	lb/ft	mm	in
AS005	0.875	0.587	395.52	15.57

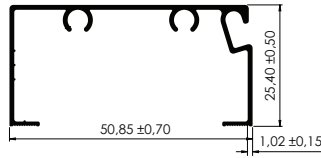

2" X 1" FLAT SPINE GROOVE (OPEN BACK)

REF.	Weight		PER.	
	kg/m	lb/ft	mm	in
AS007	0.384	0.258	271.12	10.67

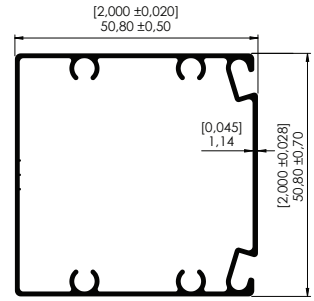

2" X 2" FLAT SPINE GROOVE

REF.	Weight		PER.	
	kg/m	lb/ft	mm	in
AS008	0.730	0.490	485.34	19.10

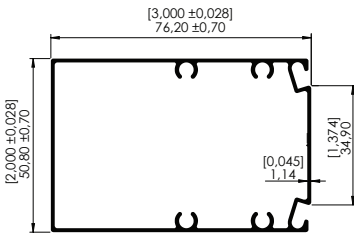

2" X 3" FLAT SPINE GROOVE

REF.	Weight		PER.	
	kg/m	lb/ft	mm	in
AS009	0.968	0.650	587.69	23.13

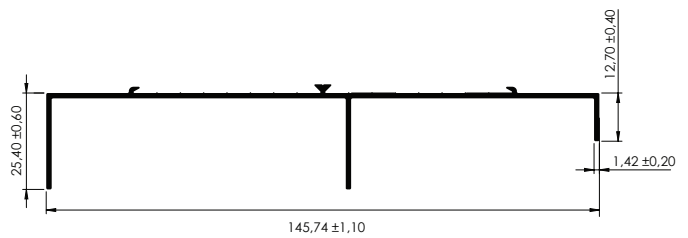

5-1/2" EXTRUDED FASCIA

REF.	Weight		PER.	
	kg/m	lb/ft	mm	in
AS010	0.843	0.566	432.27	17.01

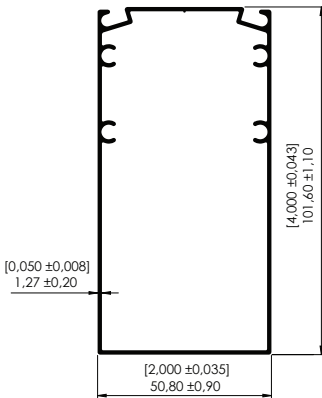

4" X 2" FLAT SPINE GROOVE

REF.	Weight		PER.	
	kg/m	lb/ft	mm	in
AS020	1.199	0.806	676.14	26.62

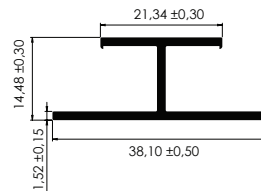

T-CONNECTOR

REF.	Weight		PER.	
	kg/m	lb/ft	mm	in
AS022	0.293	0.196	145.29	5.72

SOLAR PANEL RACKS

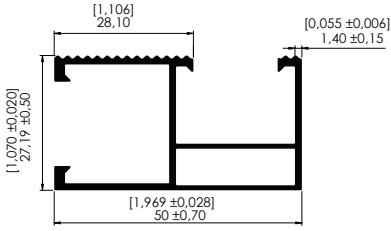

52MM X 28.7MM RAIL

REF.	Weight		PER.	
	kg/m	lb/ft	mm	in
PS001	0.604	0.406	335.04	13.19

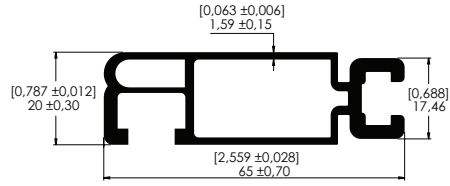

HEAVY DUTY RAIL

REF.	Weight		PER.	
	kg/m	lb/ft	mm	in
PS003	1.069	0.719	376.08	14.80

**CAN'T
FIND WHAT
YOU ARE
LOOKING
FOR?**

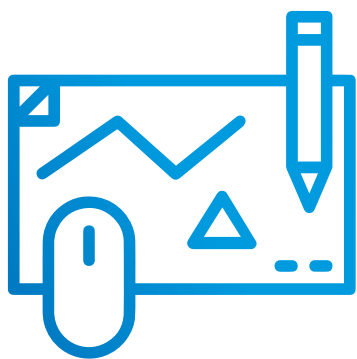

**IF THE PROFILE
YOU ARE LOOKING FOR
IS NOT IN THE CATALOG,
WE CAN DEVELOP
IT FOR YOU.**

**GET STARTED AND
CONTACT US FOR
A FREE QUOTE**

info@stakaluminum.com

AVAILABLE FINISHES



POWDER COATING



We have an automated electrostatic painting or powder coating equipment in our plant to create a hard finish that is more resistant than conventional painting. With our high application efficiency we can offer varieties of colors.

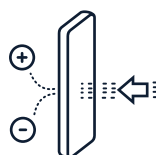
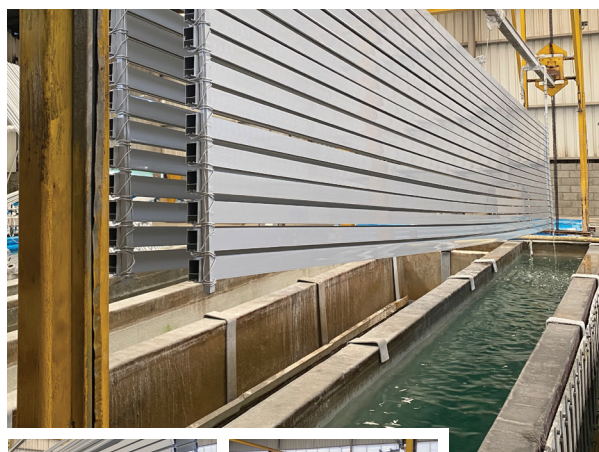

ANODIZING

Electrochemical processes that create a thick layer of natural oxide and this achieves complete protection against corrosion, resistance to abrasion, insulation to electricity and an aesthetic improvement in the finish.

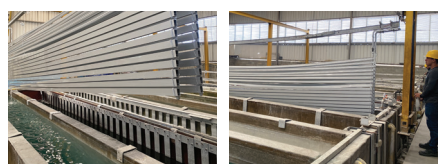



Stäk Glass and Aluminum

Call us: +1 (305) 570-1260

Write us: info@stakaluminum.com

11801 NW 100th Rd Suite 15
Miami FL 33178, USA

WWW.STAKALUMINUM.COM